

# Design of Two Flare UWB Antenna dedicated to the Research of Alive Buried Victims

JM Denoual, JM Floc'h



JP Mutzig, P. Massaloux, F. Ducasse, P. Minvielle,  
C. Labarthe

1



UMR  
6164



# Outline

- The project
- The partnership
- Goals
- CST simulation
- Measurements
- Some results

# VIPERE Project

(Vision des PERsonnes Ensevelies)

- Project financed by ANR beginning in 2007, end in august 2010
- Goals : Detection of buried persons with RADAR techniques

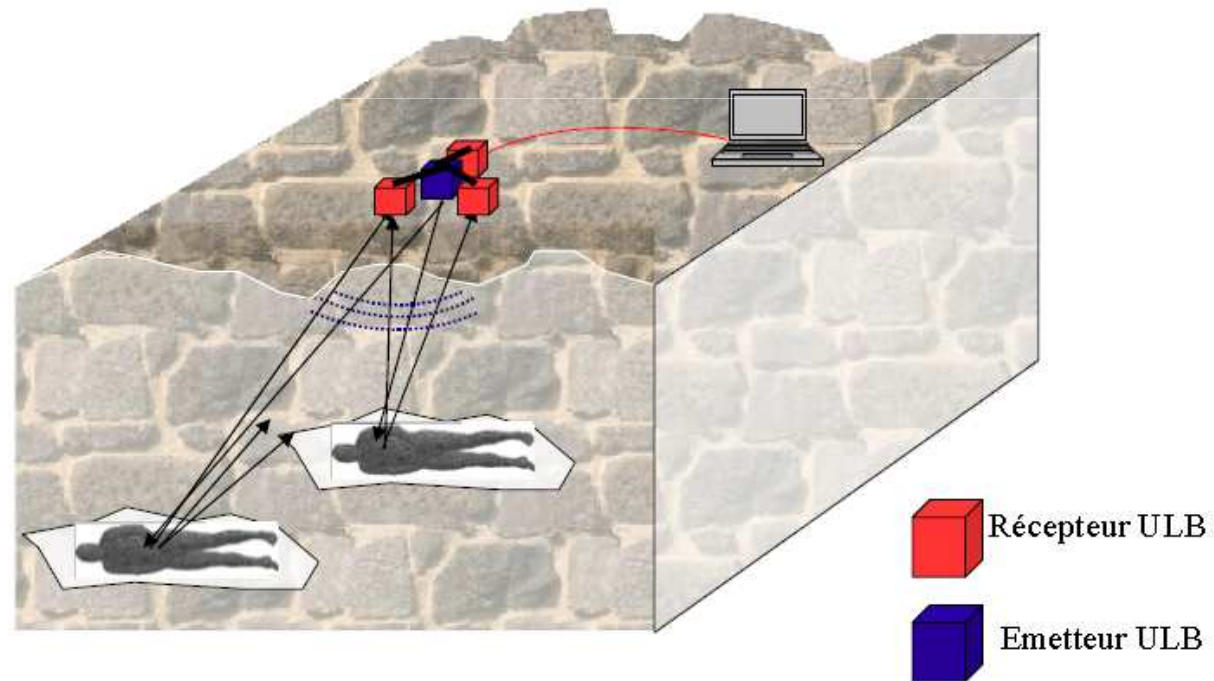

# Partnership

- CEA for antenna test
- CISTEM / XLIM for radio electric experimental and simulation data
- ETSA for Electronics
- IETR for antenna design
- MARTEC for leadership, integration and treatments

# Goals (1)

- Propagation in inhomogeneous structure
  - High attenuation
  - Multiple path, diffraction
- Detection of people with very low mobility
- Doppler treatment
- Imaging in 3D
- Light and compact system

# Goals (2)

- Radar scope 2 to 30 m
- Distance resolution 15 to 50 cm
- Maximum sensibility -150 to -165 dBm
- Respiration amplitude few mm to 2 cm
- Respiration frequency 0.1 to 0.5 Hz
- Radar UWB CW with phase coding
- Frequency repetition 100 Hz
- Code length  $2^{23}$
- Treatment gain 69 dB

# Radar schematic

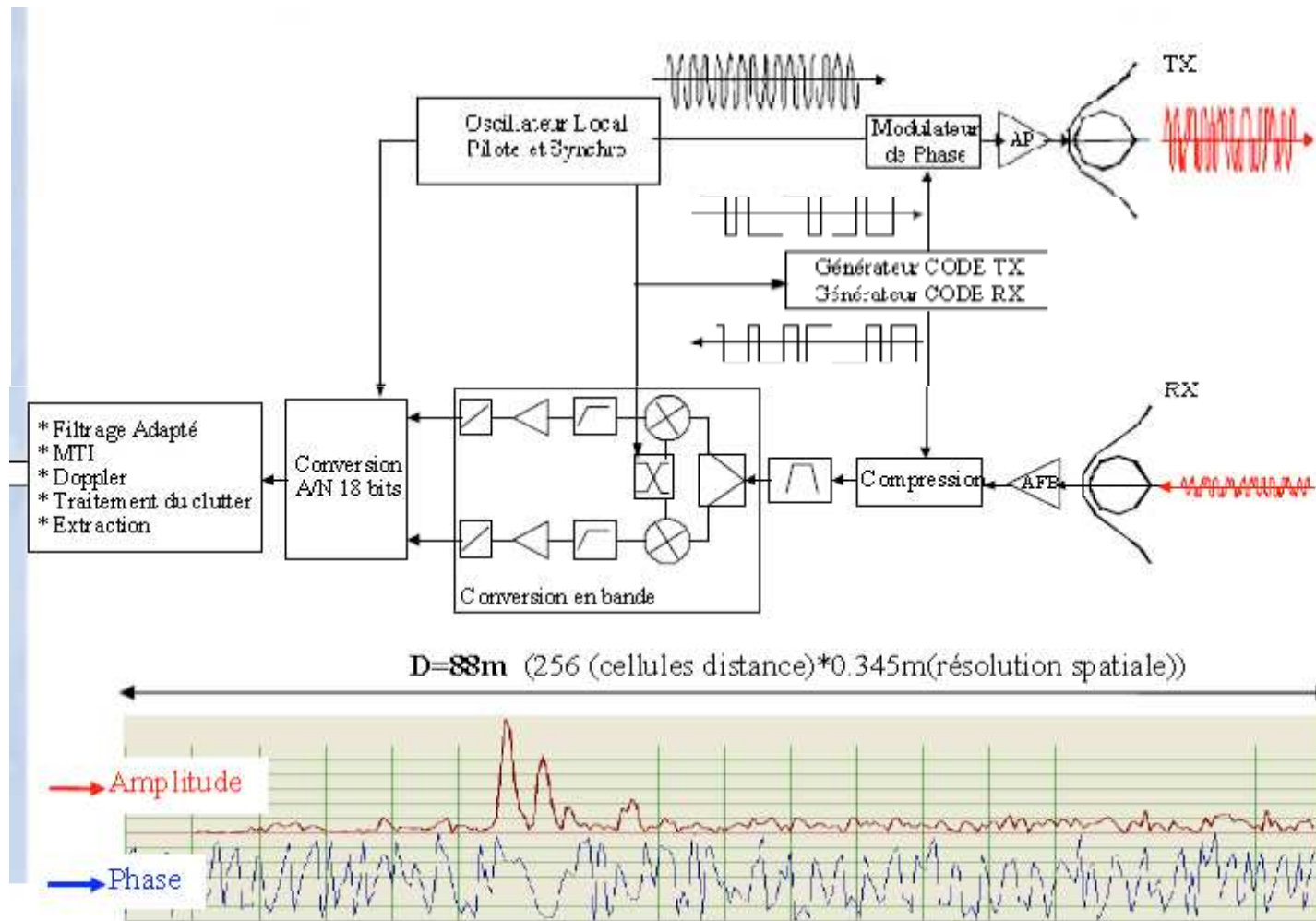

# VIPERE Antenna (1)

- UWB 300 – 3000 MHz
- Good impulse response
- Good ratio for back to broadside radiation
- Good decoupling between H and V polarization
- Good efficiency
- Light weight

Flare antenna based from the works of Boryseenko (university of Massachusetts), Amherst and Dmitriy (Sostanovsky Radio Research Company Ukraine)

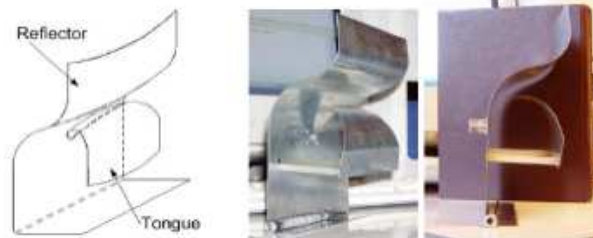

# VIPERE Antenna (2)

- Symmetric structure (2 flares)
- Damping resistance at the end of the flares
- Shape optimization
- Direct interface with emission and transmission modules

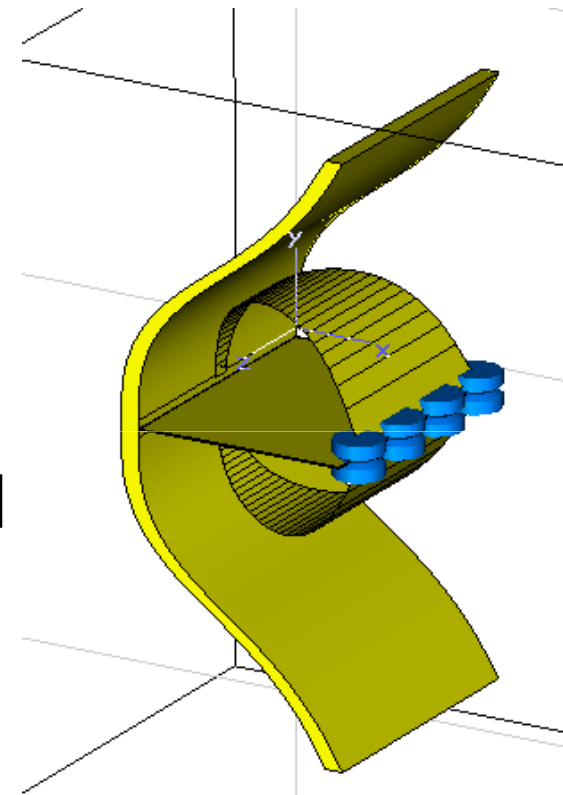
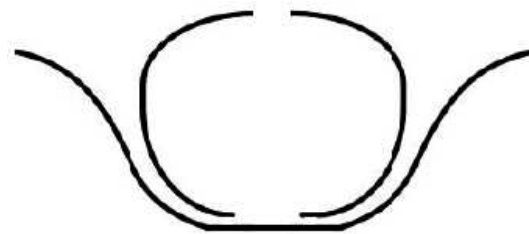

# Examples of simulation

- Simulation and optimization of reflector and flare shape in order to have
  - good reflection coefficient
  - good radiation pattern
  - good impulse response

# Antenna prototype (1)

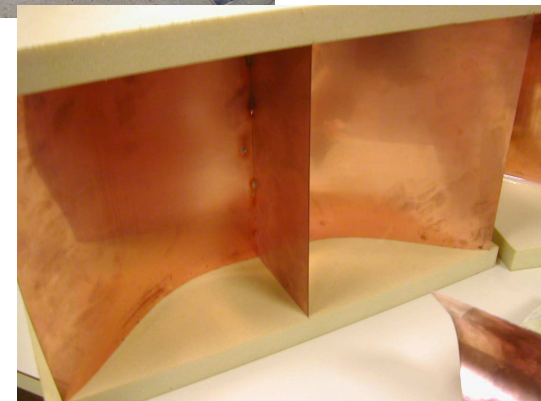
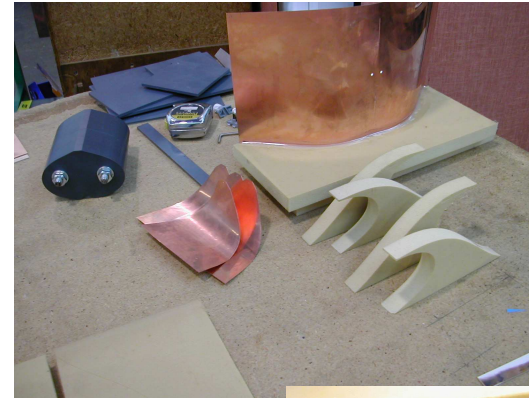
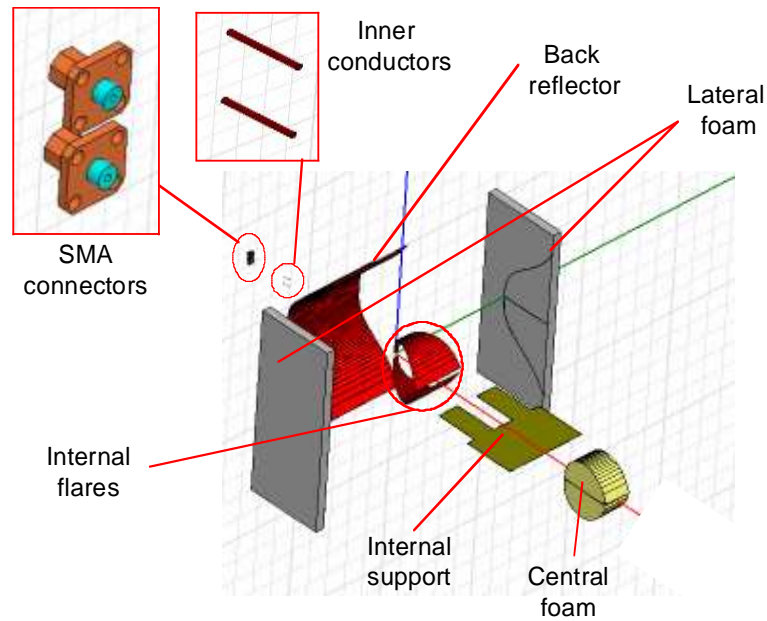

# Antenna prototype (2)



Size : 35 x 23 x 15 cm

Weight : 1.1 Kg

12

# CEA Measurement System for radiation patterns

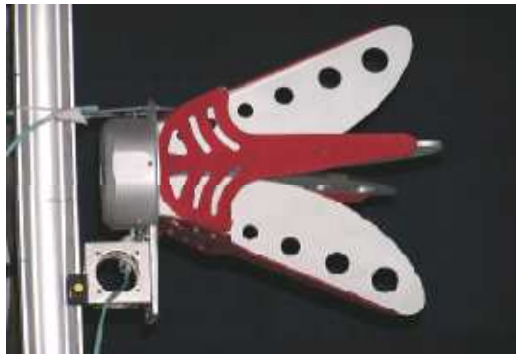

Reference Antenna  
with H and V polarization

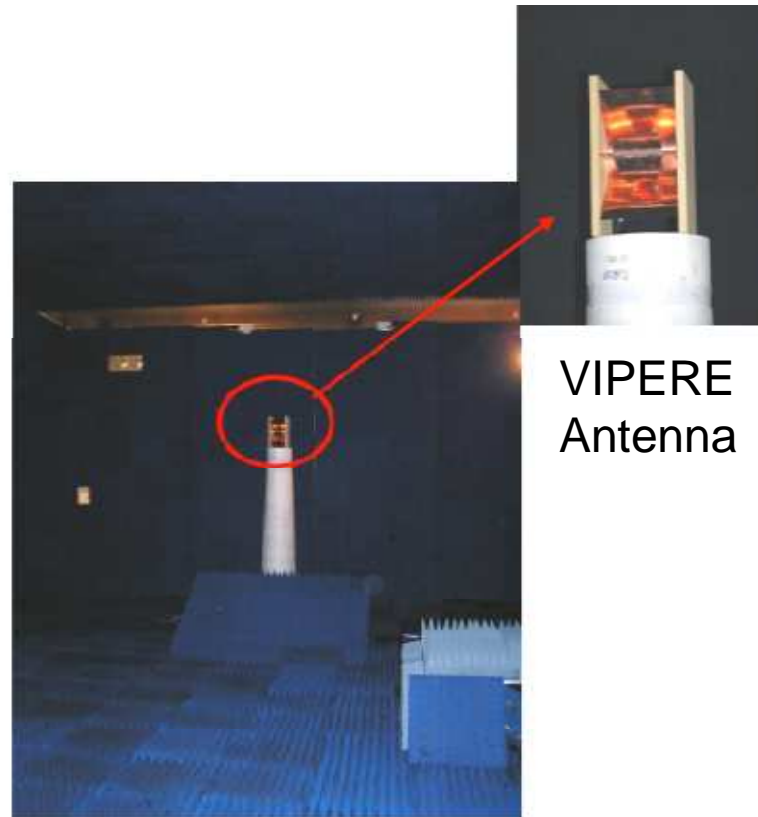

VIPERE  
Antenna

# Reflection coefficient

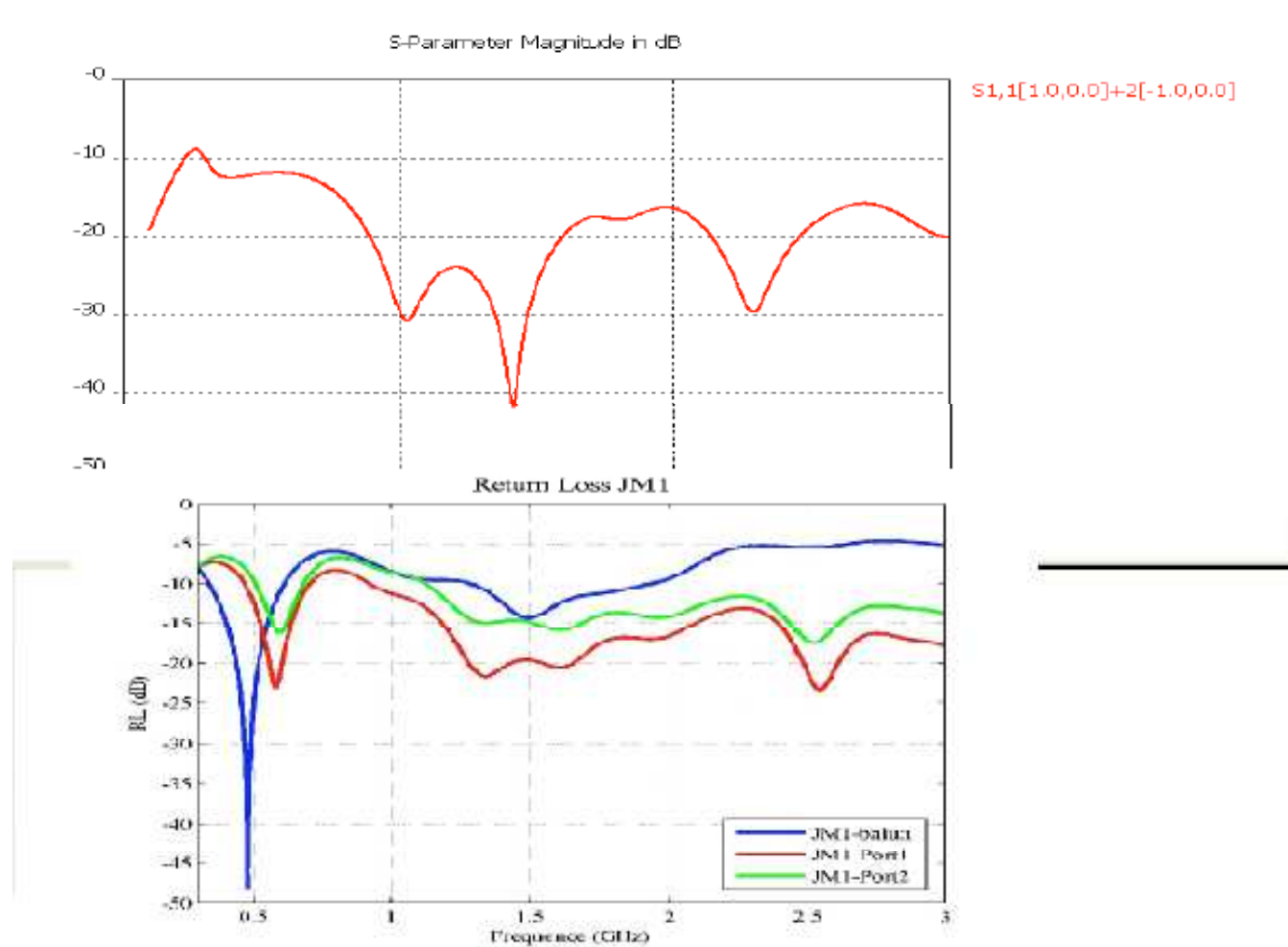

# Radiation pattern

(measurement and simulation in H and V polarization)

300 MHz

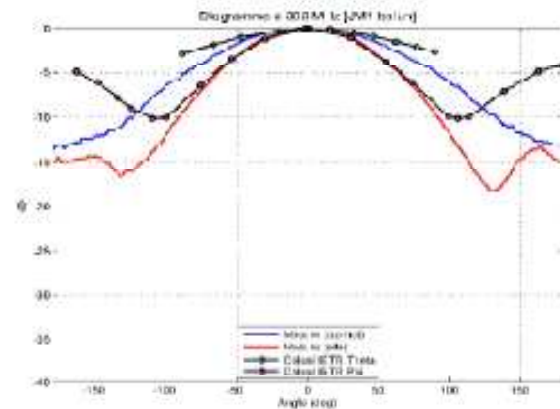

1 GHz

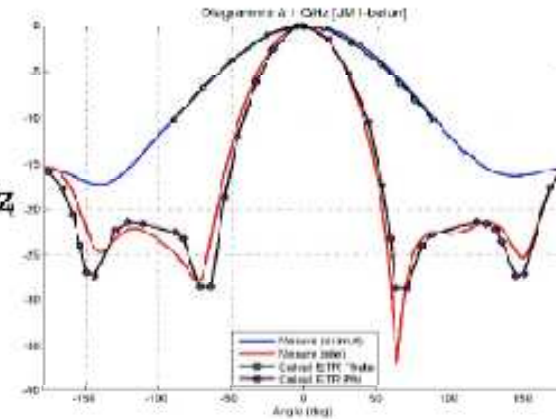

2 GHz

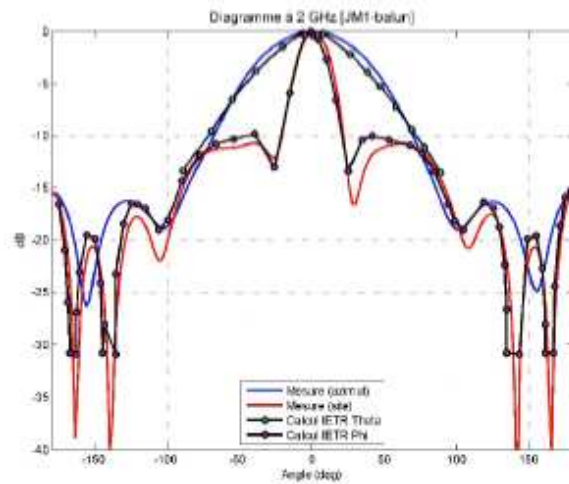

3 GHz

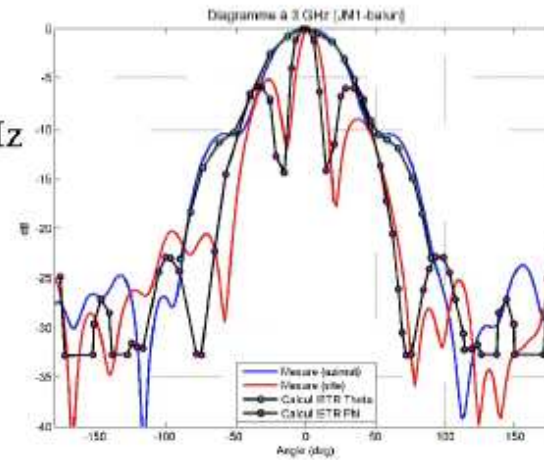

# Antenna Gain

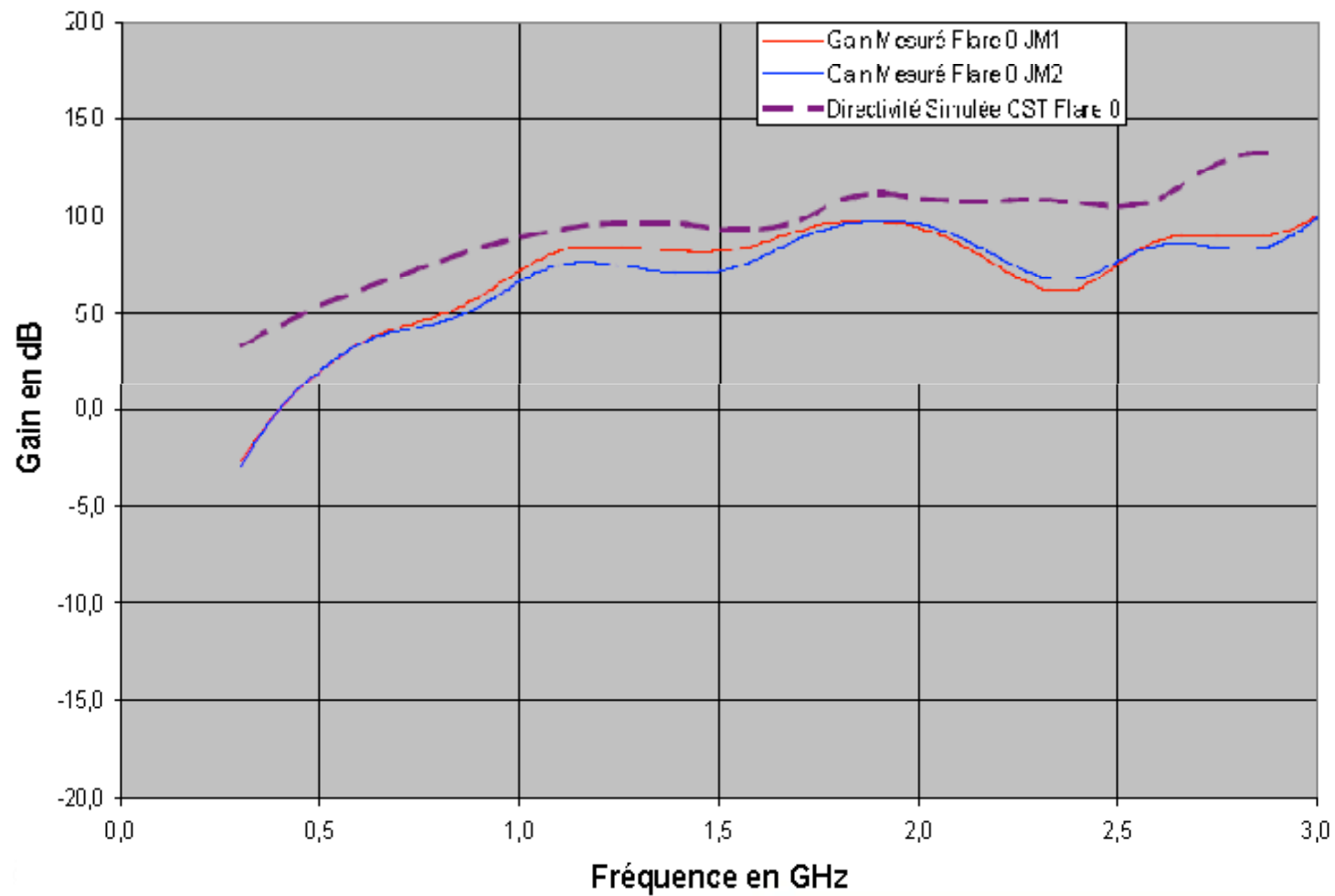

# Impulse response (1)

(simulation and measurement in azimuth and elevation)

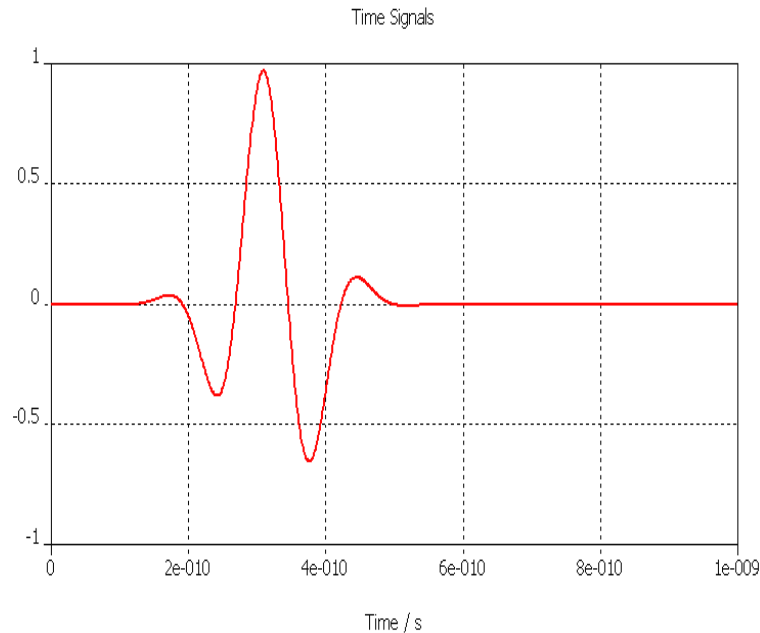

**Injected signal by CST  
for impulse response.**

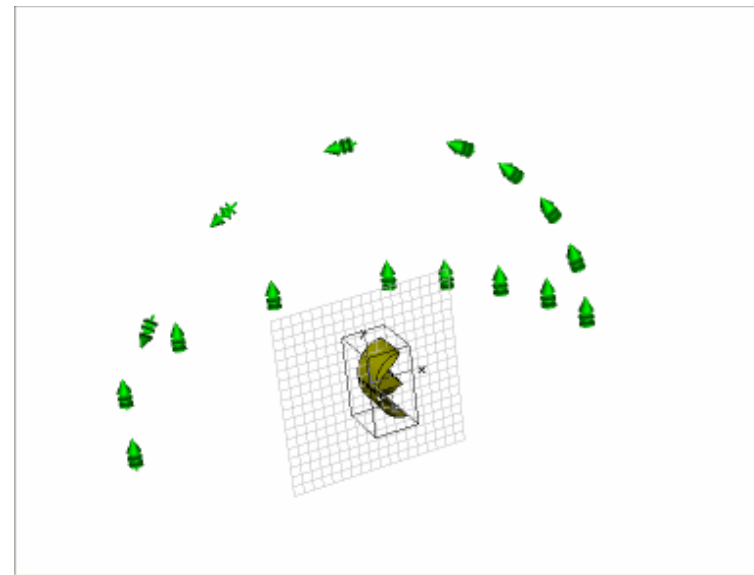

**Far-field voltage probes  
for the simulated impulse response.**

# Impulse response (2)

(simulation and measurement in azimuth and elevation)

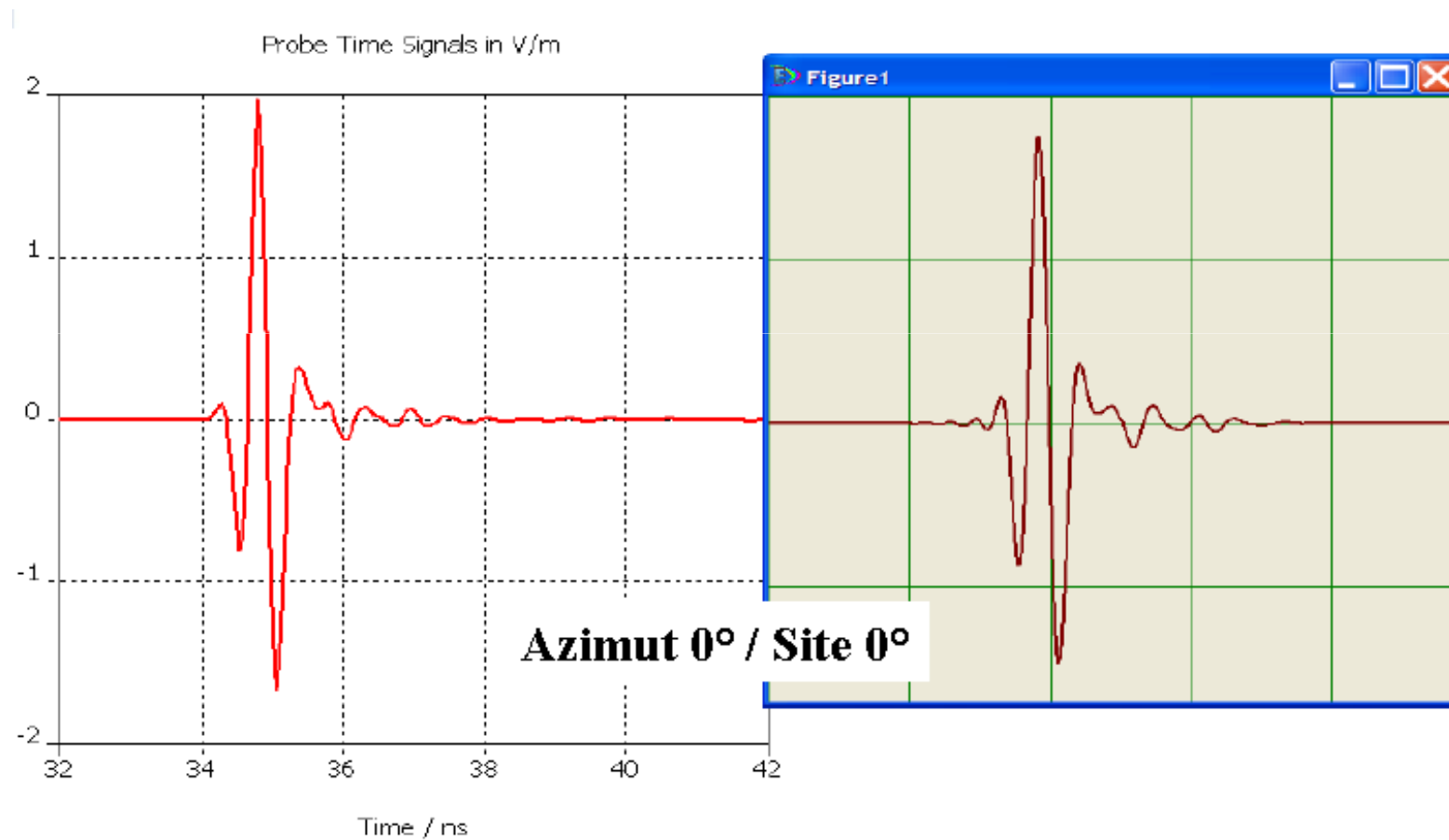

# Impulse response (3)

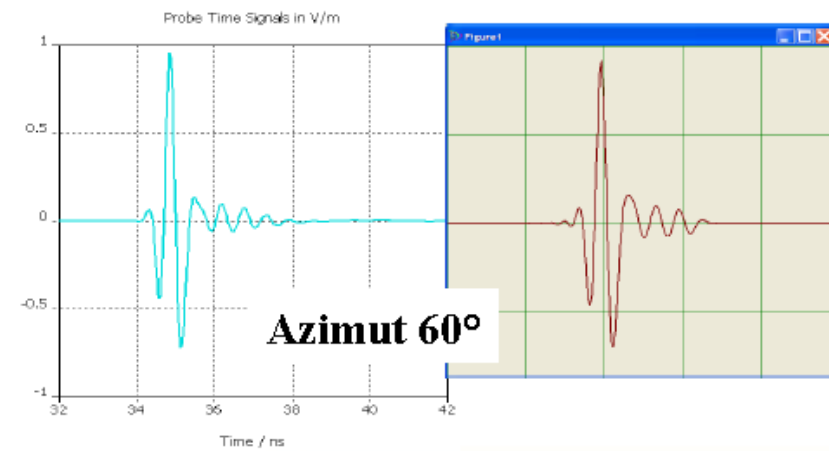
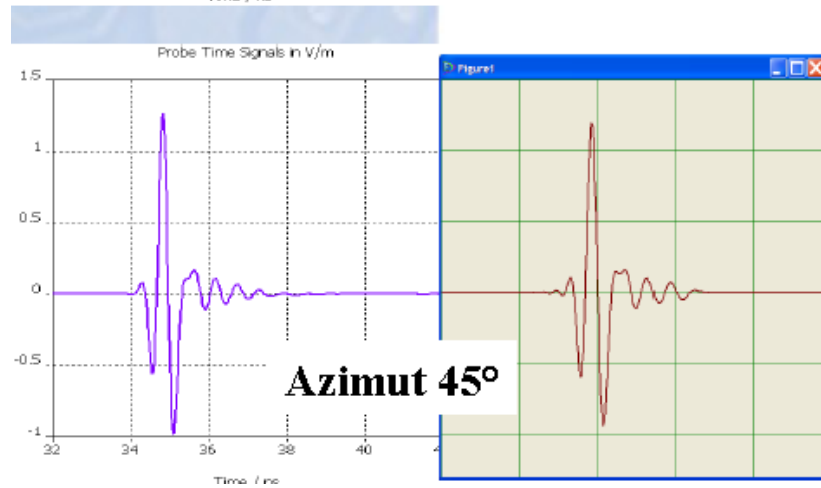
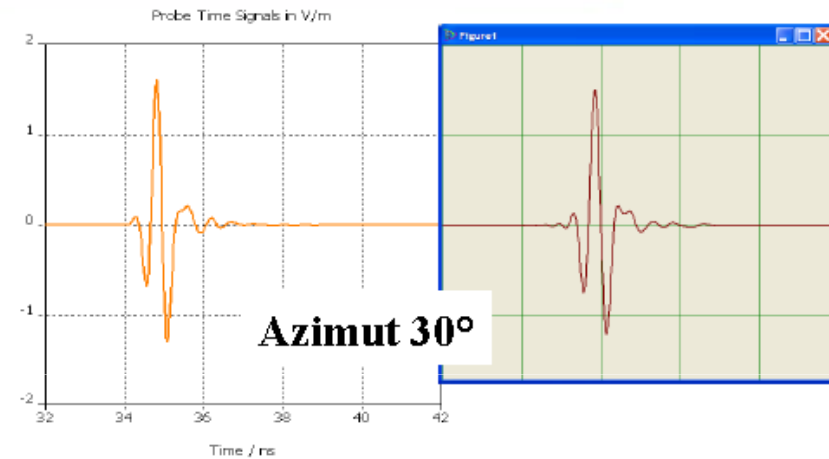
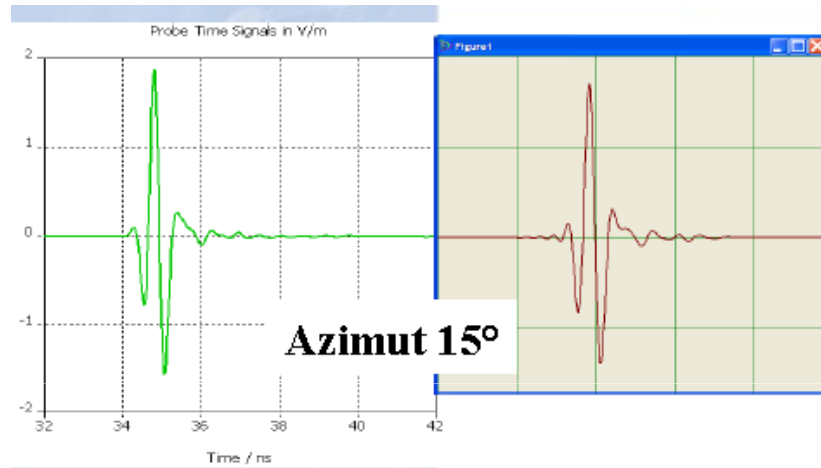

# Impulse response (5)

## Elevation

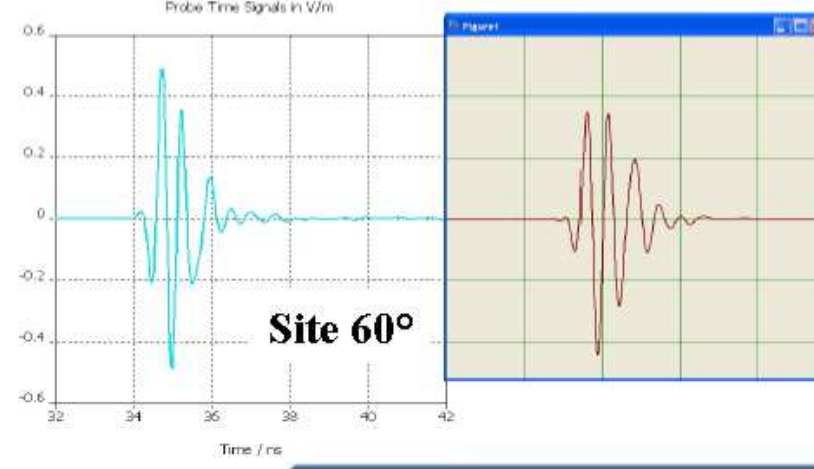
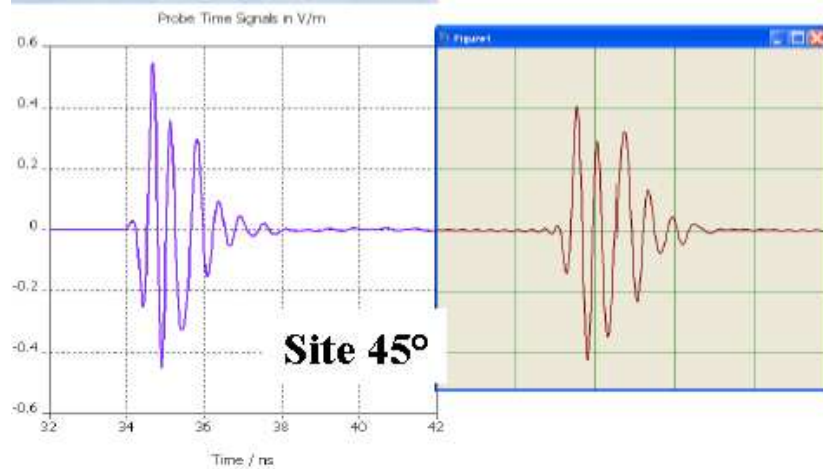
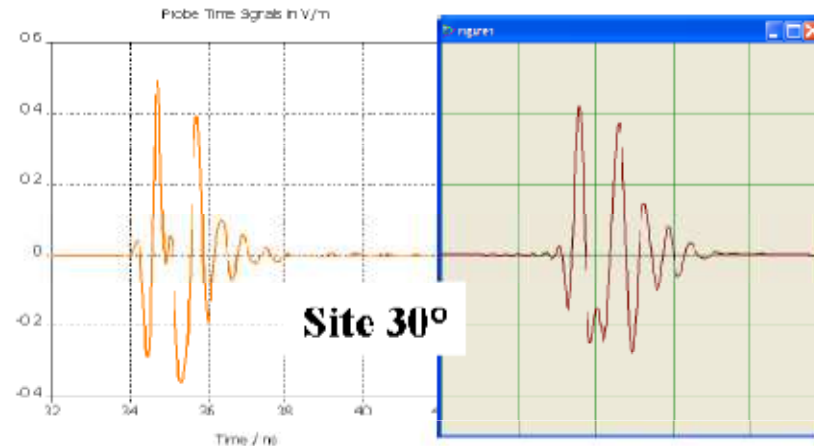
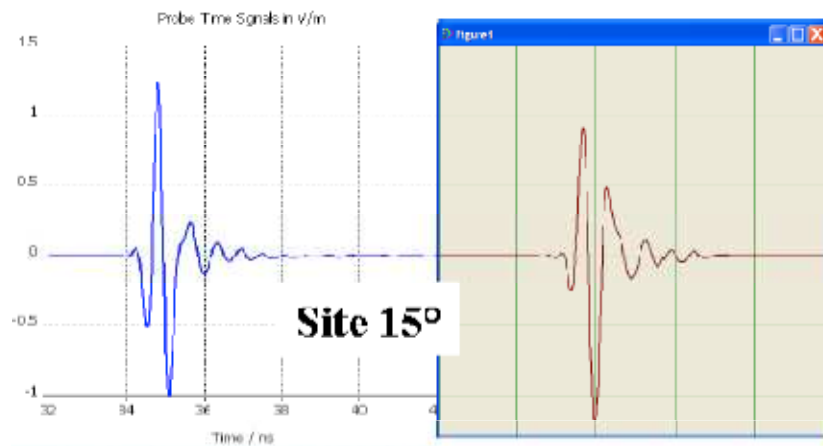

# Antenna Coupling Simulation (1)

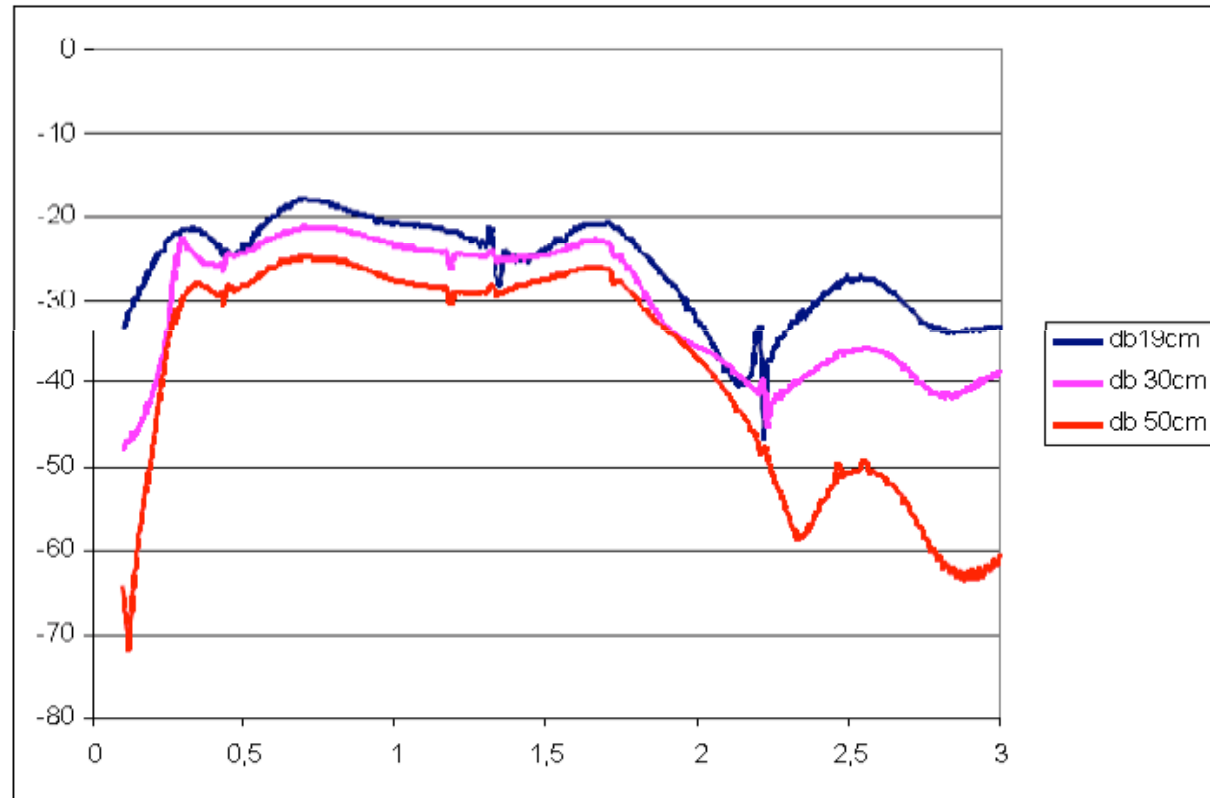
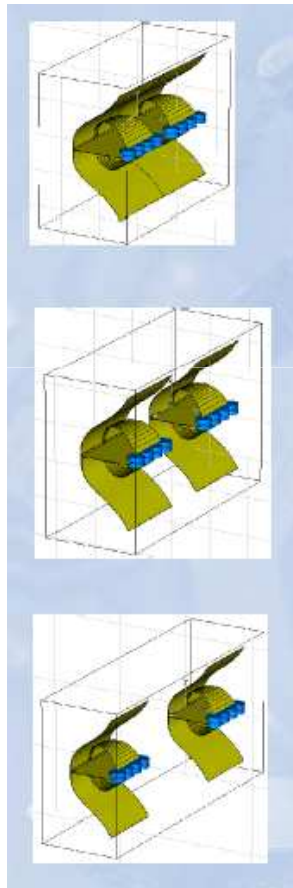

Distance center to center

21

# Antenna Coupling Measurements (1)



Horizontal coupling



Vertical coupling

# Antenna Coupling Measurements (2)

Horizontal

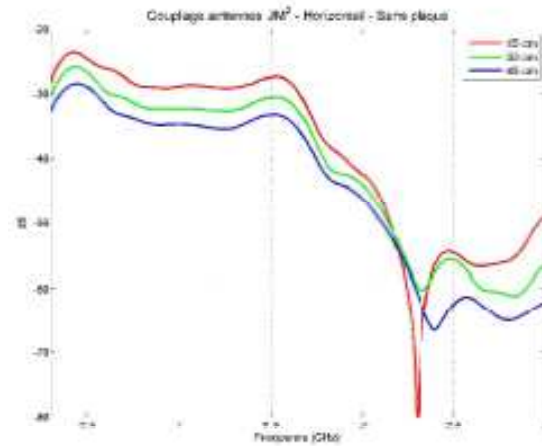

Vertical

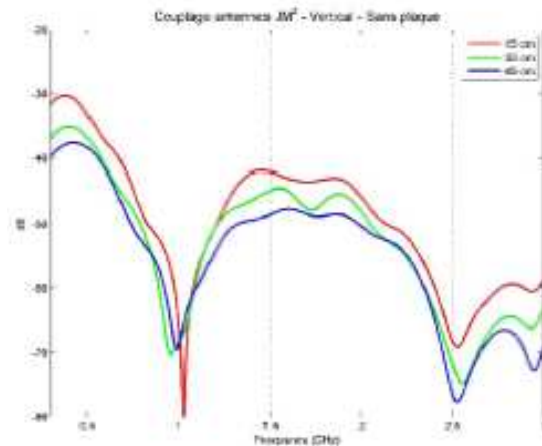

Distance :  
15 cm  
30 cm  
45 cm

# Radar Prototype

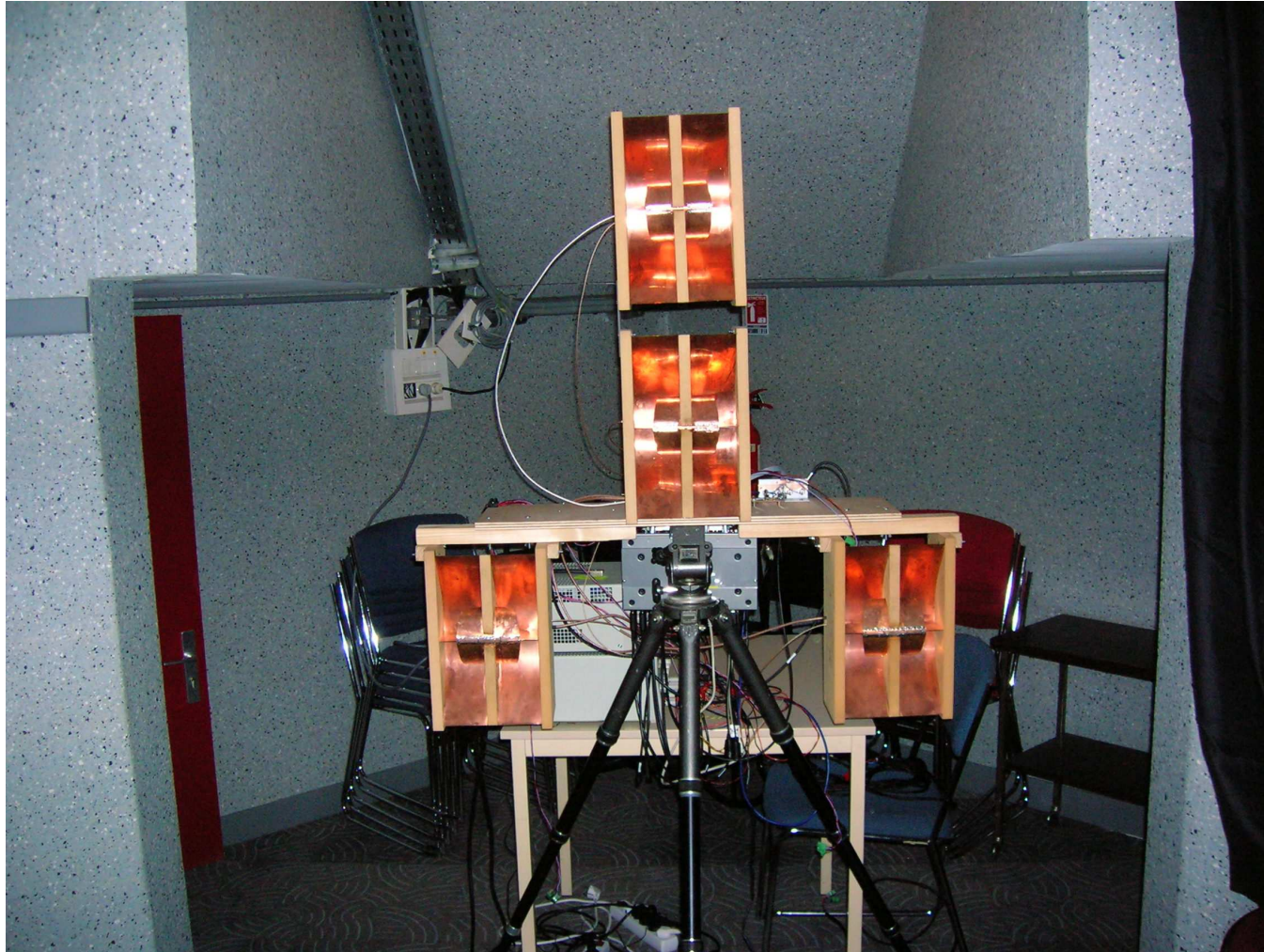

24

# Measurement example

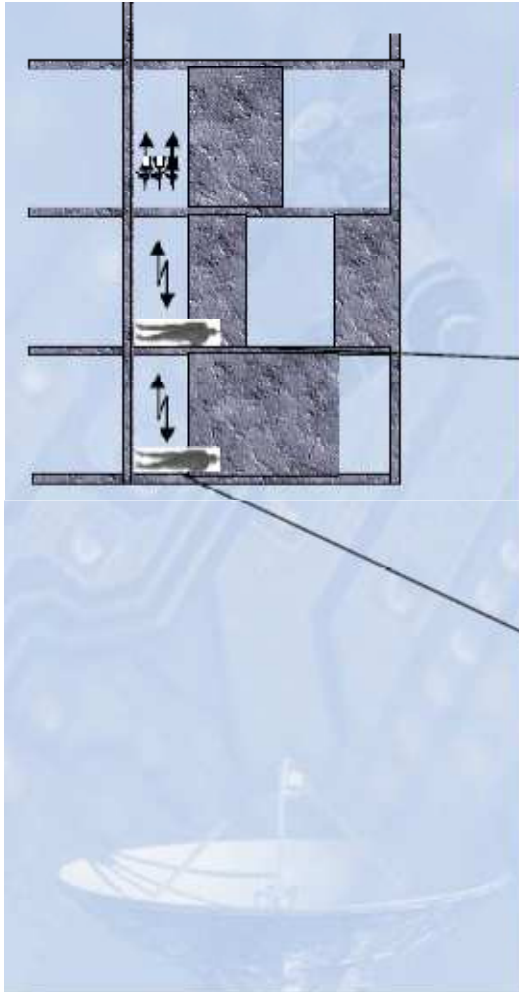

Respiration measured spectra

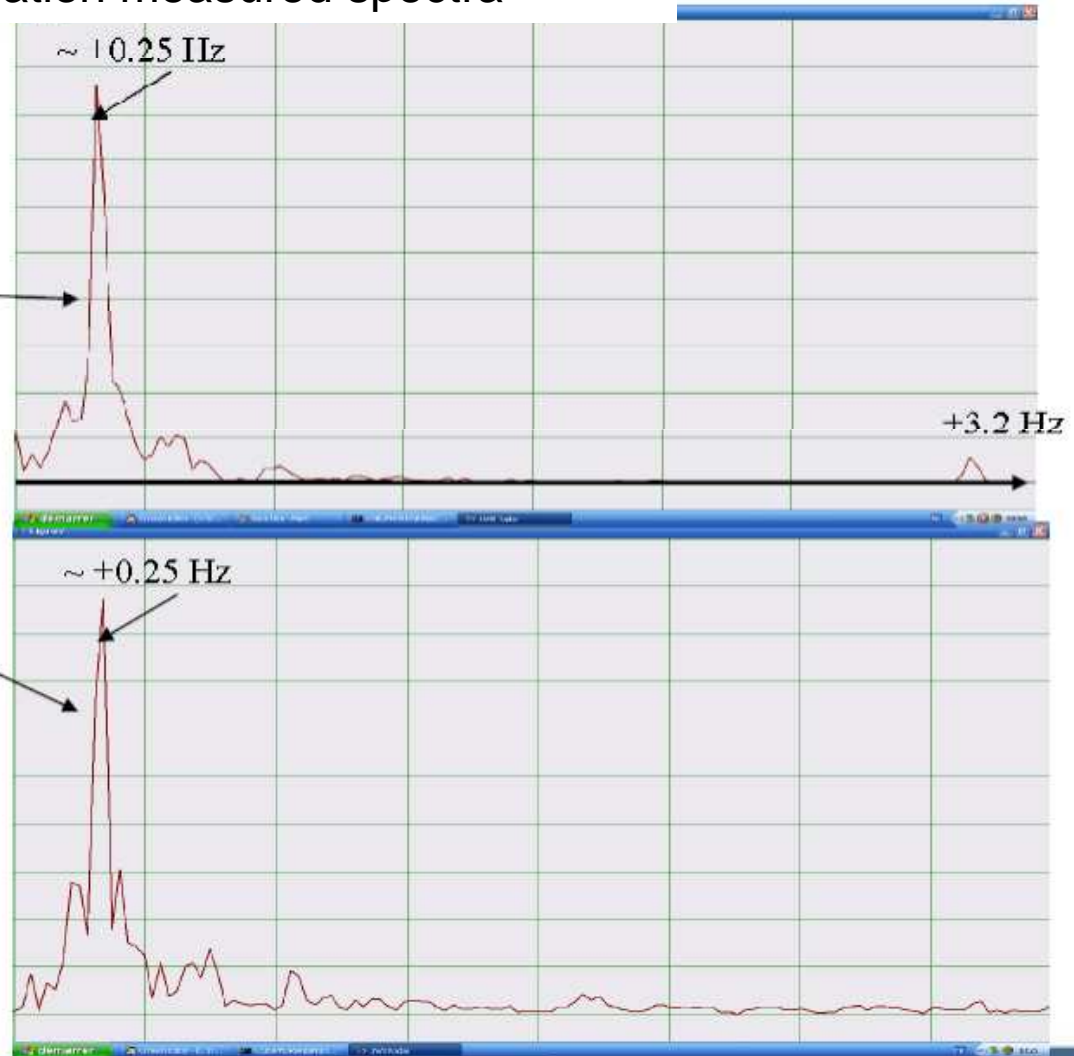

Thank you for your attention

# Antenna Coupling Simulation (2)

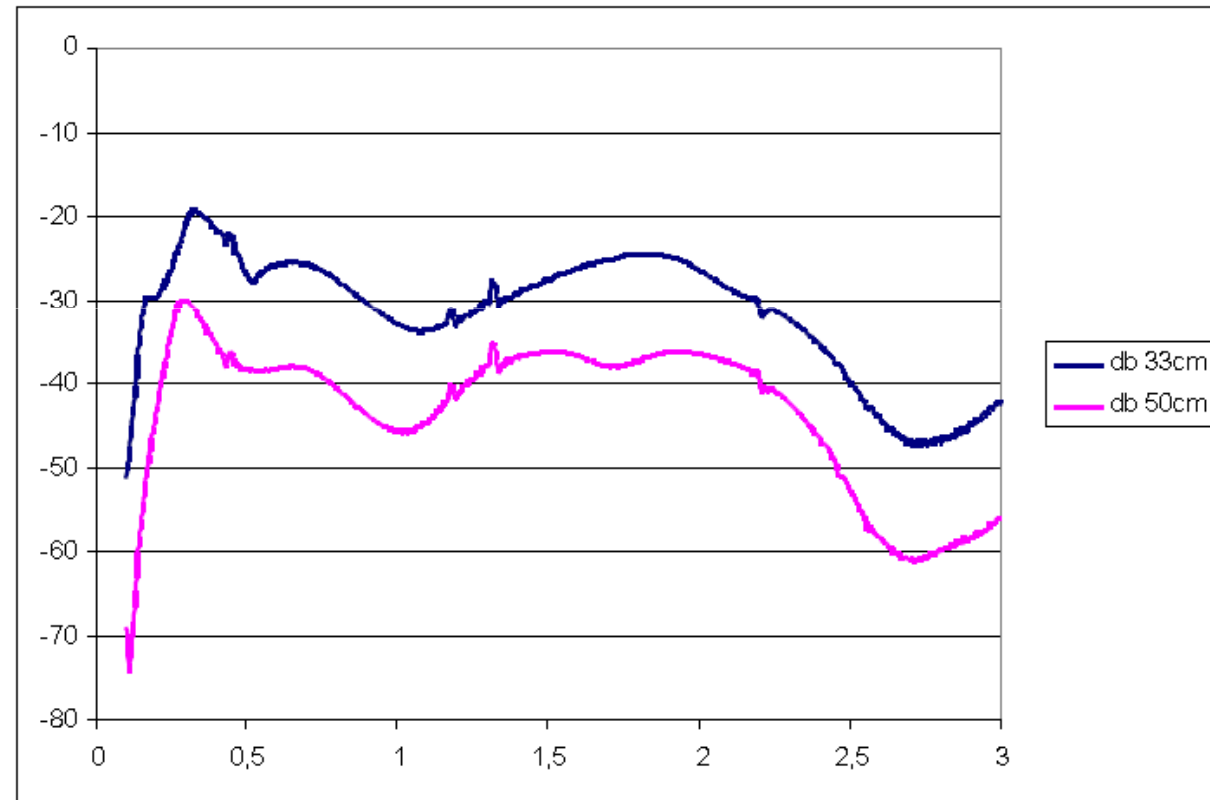
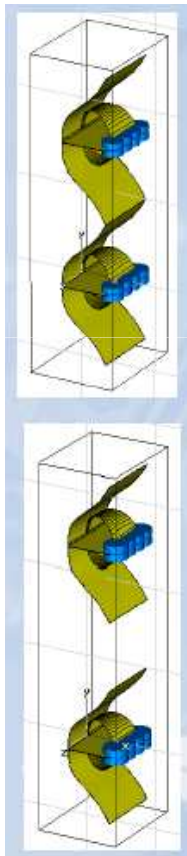

Distance center to center

27

# Polarization decoupling

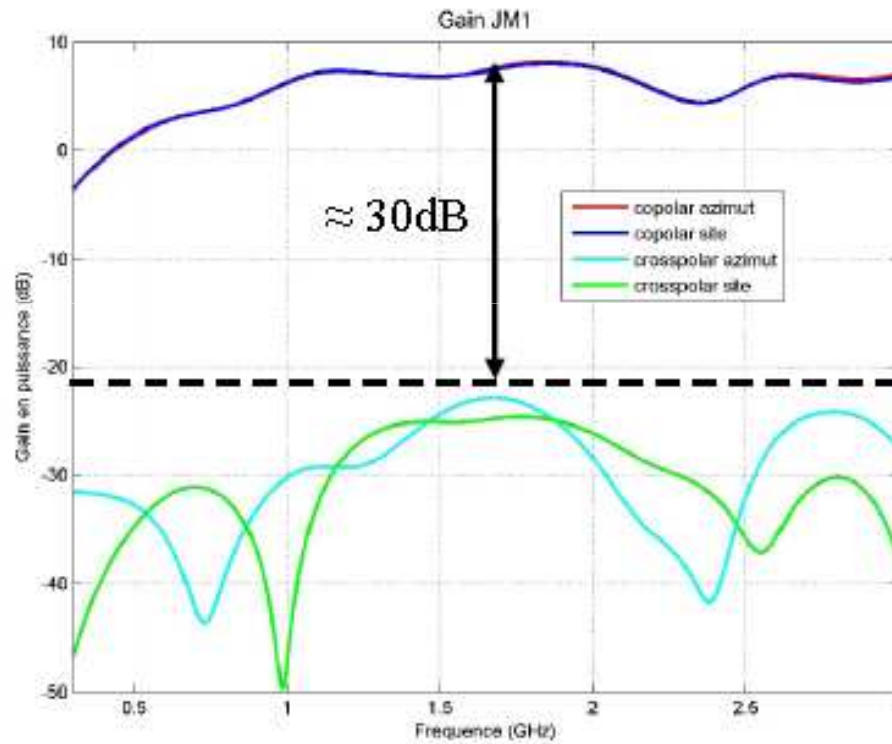

# Antenna Coupling Simulation (3)

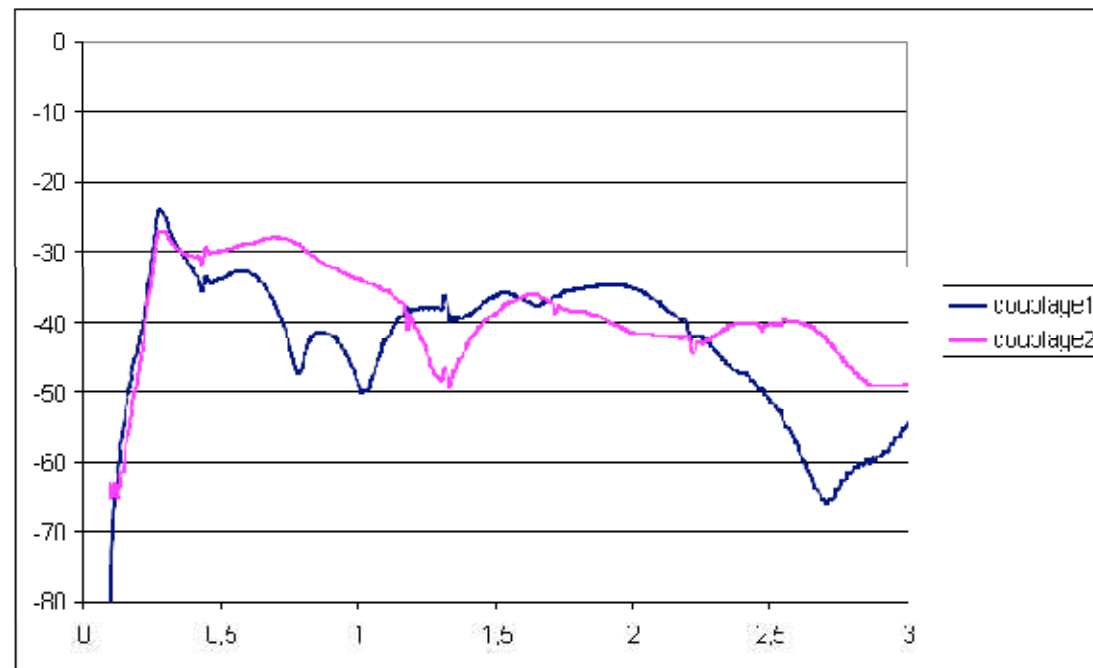
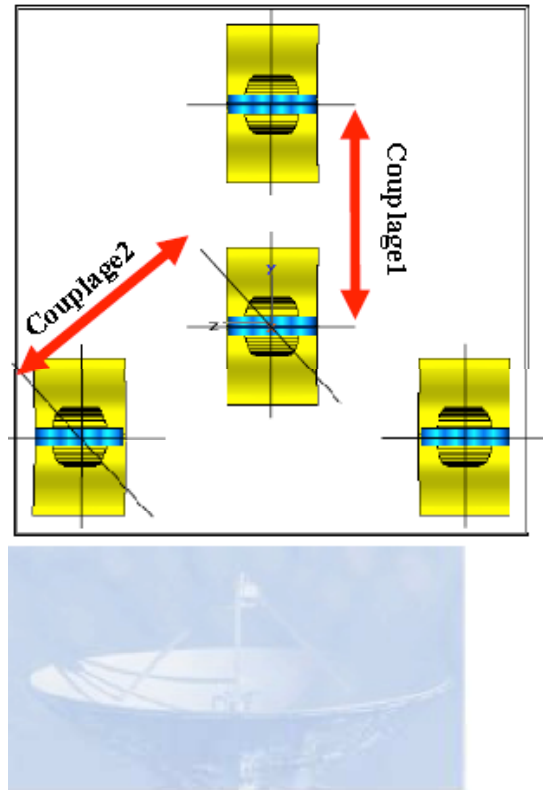

# Impulse response (6)

## Elevation

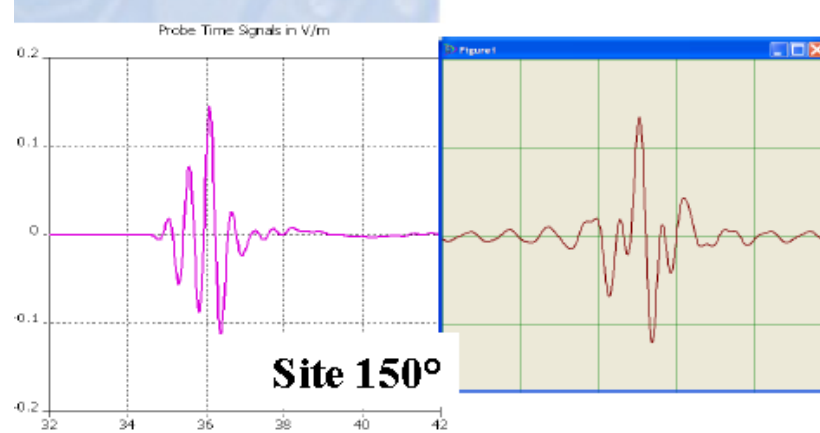
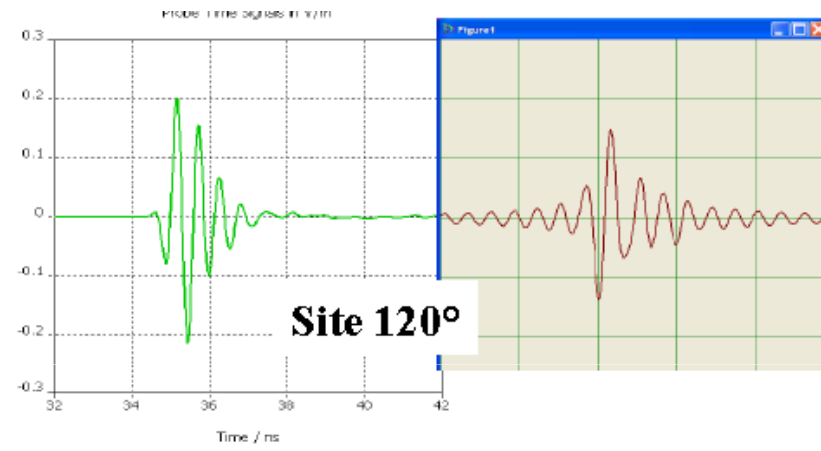
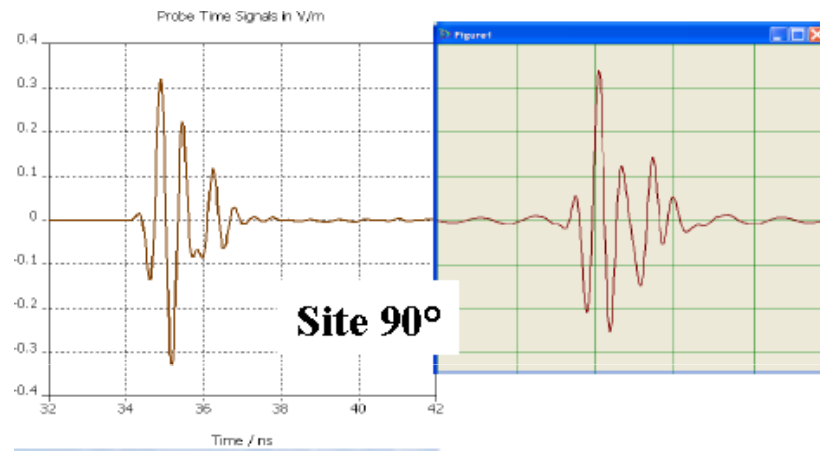

# Impulse response (4)

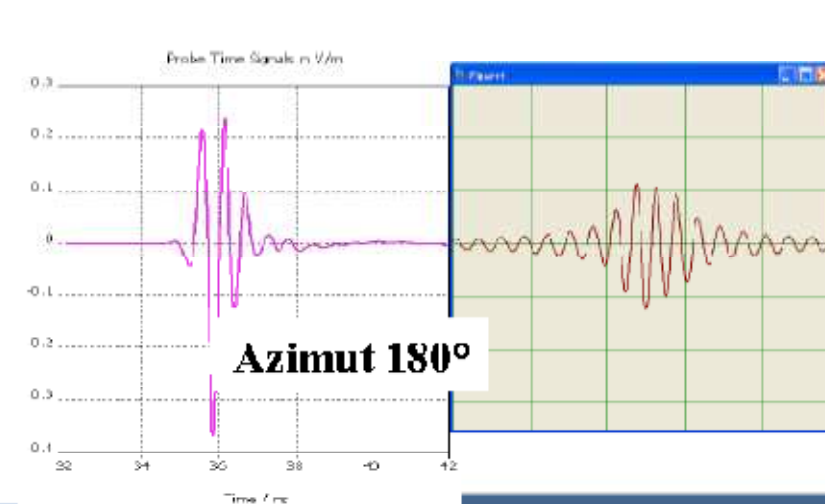
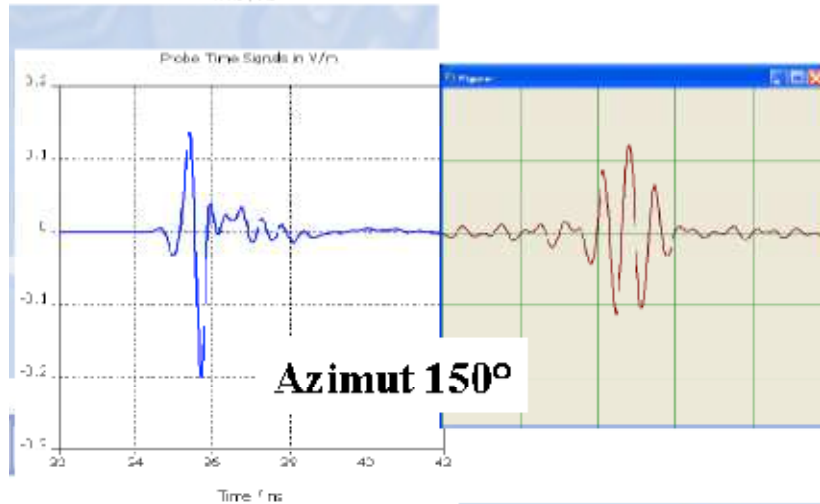
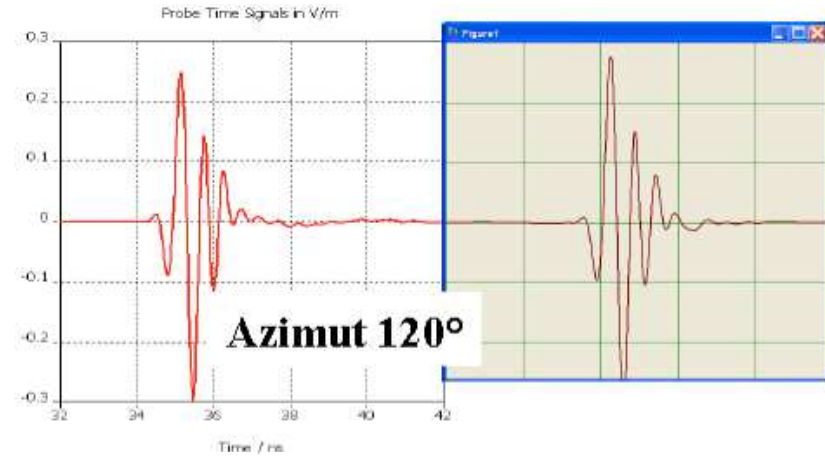
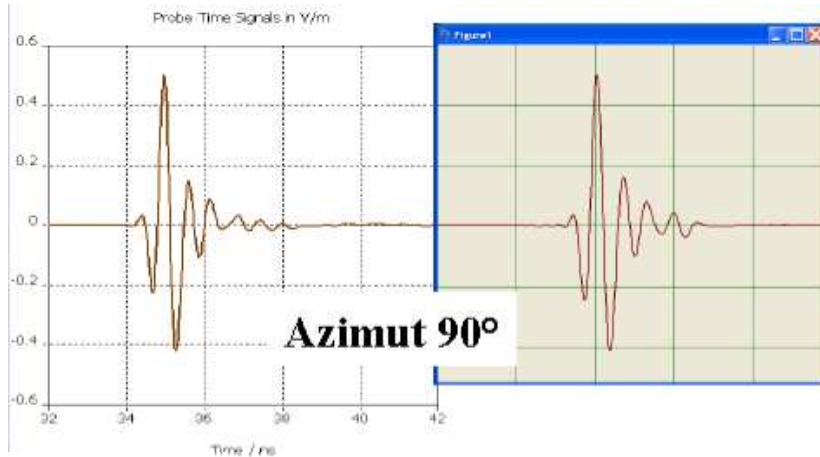

Cette Ecole propose aux ingénieurs, doctorants et chercheurs, au travers de plus de 25 heures de cours et de travaux pratiques, une approche croisée des mesures électromagnétiques d'antennes, de diffraction, en chambre anéchoïque et mettant également en oeuvre des outils (habituellement) dédiés à la CEM. Outre les aspects formation, cette semaine se veut également lieu d'échanges entre participants et intervenants.

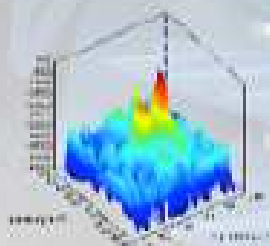

Cette Ecole comprend :

- Des cours généraux pour définir les paramètres mesurés et expliquer les principales techniques de mesure.
- Des cours ciblés présentant des mesures spécifiques et des techniques couramment utilisées.
- Des Travaux Pratiques sur les équipements de niveau national et international de IETR, des visites de plate-formes pour appréhender concrètement les mesures (mesures en bande millimétrique ; imagerie SAR ; mesures champ proche ; chambre réverbérante).
- Une "journée experts", gratuite et ouverte aux étudiants de Master et aux entreprises, consacrée aux exposés d'experts internationaux le Jeudi 6 octobre (inscription nécessaire).

**Programme préliminaire**

Introduction à la mesure d'antennes. L. Le Coq - IETR	Introduction à la mesure de diffraction. J.M. Geffrin – Institut Fresnel
Outils et approche CEM. P. Besnier, C. Lemoine - IETR	Imagerie SAR L. Ferro Famil - IETR
Antennes ULB pour les radiocommunications – Mesure de fonctions de transfert. C. Roblin – ParisTech C. Delaveaud – CEA LETI	Mesures de SER. DGA
Advanced spherical near-field antenna measurements: theory, practice, and applications. S. Pivnenko, DTU, Danemark	Antenna Measurement implementation, challenges and solutions. S. Gregson, NSI, UK



**Inscription**

Ouverture des inscriptions : 15 Mai 2011.  
 Date limite d'inscription : le 18 Septembre 2011.  
 Tarif : plein : 400 €  
 réduit\* : 300€

\* le tarif réduit s'applique aux membres du club des partenaires du Gdr Ondes.

**Site Web**

[www.ietr.fr/spip.php?rubrique417](http://www.ietr.fr/spip.php?rubrique417)

Bourses : Les étudiants inscrits avant le 1er Septembre 2011 peuvent obtenir un soutien financier de la part de cette école d'automne du Gdr Ondes (prendre contact avec l'organisation).

Cette Ecole du Gdr Ondes est également soutenue par IETR, l'Ecole Doctorale Matisse, le GIS SISCAM et Rohde & Schwarz.

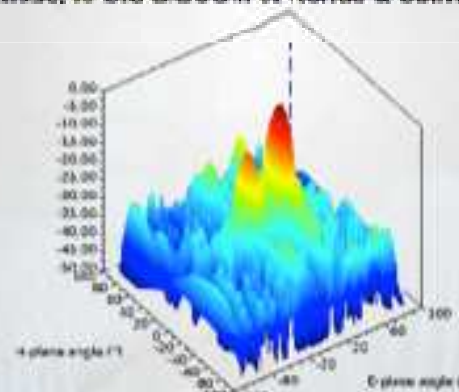

**Contacts**

**Organisation** [laurent.le-coq@univ-rennes1.fr](mailto:laurent.le-coq@univ-rennes1.fr)  
[jean-michel.geffrin@fresnel.fr](mailto:jean-michel.geffrin@fresnel.fr)

**Inscription** [laurent.le-coq@univ-rennes1.fr](mailto:laurent.le-coq@univ-rennes1.fr)  
[joelle.drouet@univ-rennes1.fr](mailto:joelle.drouet@univ-rennes1.fr)

